

HOME OWNERS MANUAL



Residential Wastewater Treatment System

Model: SA – 500 GPD

This system has been tested in accordance with the criteria as set forth in ANSI/NSF Standard 40 and is hereby certified as conforming with requirements for classification as a Class 1 Wastewater Treatment Plant.

NATIONAL WASTEWATER SYSTEMS INC.
6754 Hwy 90 East
Lake Charles, La 70615
(337) 439-0680

UPDATED
JAN. 3, 2002

SOLAR AIR

Notes

HOW THE PLANT FUNCTIONS

The *SOLAR AIR* single family wastewater treatment plant is an extended aeration activated sludge process. This type of treatment depends primarily upon the use of air that is introduced to the wastewater from your home as soon as it enters the treatment unit. When air is introduced it promotes the growth of aerobic organisms that breakdown the organic solids in the wastewater producing inorganic and stable organic solids. The use of air is called aeration and this aeration provides dissolved oxygen, mixing of the wastewater and enough time for the organisms or bacteria to breakdown the organic solids that have entered the wastewater treatment plant.

In the aeration chamber the wastewater is brown in color. This caused by the return of sludge from the clarifier. As the wastewater leaves the aeration chamber it enters a quiet zone where no mixing occurs. The quiet zone is referred to as a clarifier.

In the clarifier the solids separate from the liquid and settle to the bottom of the clarifier, that matter is called sludge. This sludge contains dissolved oxygen and this oxygen activates the bacteria it contains. This activated sludge is returned to the aeration chamber to be re-mixed. The sludge mixes with the incoming wastewater and this mixture of return sludge and wastewater is referred to as mixing liquor. This mixed liquor flows back into the clarifier, the solids separate and return again to the aeration chamber.

The water that separates from the solids in the clarifier and flows out of the wastewater treatment plant is referred to as the effluent.

PLANT INSTALLATION INSTRUCTIONS

Prior to installation, all state and local laws and regulations must be complied with. It is the **owner's** responsibility to obtain any required permits.

1. Inspect entire wastewater treatment plant and equipment for defects such as cracks, chips, or broken lines. Use equipment parts list to insure that all required parts are on site.

2. Select location of plant site that is accessible to the home sewer discharge line, at least ten (10) feet from the home foundation in an area that will not receive vehicular traffic. Prepare and excavate the site having a hole at least one (1) foot larger than the wastewater treatment plant and a depth that will allow for sufficient coverage. The building sewer outlet will control the depth of the plant. The unit must be level for proper operation; be sure you have a smooth, level surface for a base on which to set the unit. Make sure that the installation of the electrical blower motor is installed on the top of the sewer plant or on the side of the house, no more than 50 feet away from the house in a well-ventilated area.

3. Carefully place the unit into the ground (excavated area). At this time the building sewer line and the wastewater plant discharge may be installed.

Service Dates

Only authorized service technicians may perform the needed repairs without voiding the Service Warranty. Service calls must be dated, stamped and signed by an authorized service technician.

Installation Date	Installer	Auth Stamp	Technicians Signature

Service Dates	Service Dealer	Auth Stamp	Technicians Signature

This manual may not be reproduced in whole or in part without the expressed written consent of National Wastewater Systems, Inc.

Failure Sensing

The audio/visual alarm activates when one or more of the following conditions occur.

1) A high water condition tips the alarm float in the up position.

2) A low-pressure condition is detected due to:

- a) No water or low water level in the aeration chamber
- b) A faulty compressor
- c) A break or leak in the airline
- d) A faulty pressure switch

3) No compressor power due to:

- a) Compressor on/off switch in the off position (the on/off switch also functions as an alarm test switch when switched to the off position.)
- b) A faulty power source tripped breaker, etc.

If an alarm condition occurs, perform simple checks first.

1) Is the compressor running?

- Yes**
- a) Is the water level high enough to suspend the alarm float above the horizontal position?
 - b) Is the water level in the aerator chamber high enough to provide back pressure on the airline?
 - c) Is there a break or leak in the airline?
- No**
- a) Is the compressor on/off switch in the on position?
 - b) Is the compressor power source breaker tripped?

- 4. Insert the building sewer line until it extends approximately 2 inches inside the unit through the inlet opening (opening at highest elevation). Next, glue 4" PVC discharge pipe into the effluent end opening (opening at lowest elevation).
- 5. Seal or grout building sewer inlet to the plant with waterproof, watertight sealant making sure the exterior tapered void is completely filled with sealing material. The two piece concrete tank has a tongue and groove that should be sealed with "Preformed Flexible Butyl Mastic Sealant".
- 6. Install the air blower in a dry location no more than fifty (50) feet from the system.
- 7. Install ½ inch PVC airline from the air blower to the ½ inch PVC air diffuser bar. Permanently affix all PVC connections with PVC cement. The air blower discharge piping should be buried at least ten (10) inches, after line has been inspected for air leaks (refer to step no. 11).
- 8. The electrical controls are contained in a watertight enclosure; therefore it may be installed in any above ground area where the light is visible to the owner during the course of a normal days activities. All wiring must comply with applicable standards.
- 9. Install risers and riser covers at least 2" above natural grade. Carefully backfill around the plant placing the fill material up to the riser. Use extra precaution not to damage the plant and/or any of the piping.
- 10. Fill the plant with water to the level of discharge.
- 11. Turn on air blower and check air piping and fittings for leaks. This can be accomplished by preparing a saturated solution of soap and water and applying to the entire run of pipe and fittings. Make visual observation for bubbles. If no bubbles are observed, the piping and fittings are airtight. If a leak is detected, make repairs and retest.
- 12. Backfill the air blower discharge line ditch, influent, and effluent line ditches and the rest of the plant excavation

DURING VACATION OF EXTENDED LEAVE FROM RESIDENCE
DO NOT TURN SYSTEM OFF, THIS WILL CAUSE SYSTEM TO
HAVE A BAD ODOR, DUE TO THE TIME SPAN FOR START UP OF
SYSTEM.

OWNER'S RESPONSIBILITY

It is the **owner's** responsibility to operate the *SOLAR AIR* wastewater treatment plant to the best of their ability only residential wastewater: (human body waste, and liquid waste generated by occupants of an individual residence can be used in system.) To insure proper operation and minimize problems, the following materials should not be allowed to enter the system.

1. Strong detergents, disinfectants, chlorine tablets in toilet tank, or bleaches (other than small amounts used in day to day house cleaning and laundries). Follow manufacturer recommended amounts when using the above mentioned items.
2. Do not allow any disposable items such as: diapers, tampons, sanitary napkins, rubber products, large quantities of paper products, tobacco products, or similar items in the system.
3. Do not allow coffee grounds, chemical wastes, oils, or **grease** (such as cooking grease) into the system.
4. The discharge from any type of water softeners or similar equipment.
5. **IMPORTANT!** Keep ants away from the blower and control panel.
6. **In the event of problems, it is the owner's responsibility to contact the installer/maintenance provider in a timely fashion. Installer's name can be found on the front of the control panel, in the (Distributed By) box. Serial number can be found on the data plate of the timer box.**

WASTEWATER TREATMENT PLANT START-UP

The *SOLAR AIR* wastewater treatment plant should be filled with clean water, usually from the homeowner's water supply. As stated in the installation instructions, once all of the proper connections have been completed, the tank has been filled with water and the blower is turned on, the system is now ready to be operated.

It should be expected for the start-up process to take ten to twelve weeks to develop a population of microorganisms or bacteria that can properly digest the wastewater from normal household use. **There will be an odor during this stage. If the odor persist contact your installer or maintenance provider.**

MAINTENANCE SCHEDULE

The *SOLAR AIR* wastewater treatment plant can be operated and maintained with a minimal amount of problems or cost, if the following procedures are performed on a routine basis.

1. Daily – Check warning light for motor malfunction or failure. If the amber light is **ON**, it's an indication of a failure or a malfunction of the motor or abnormal water level. If **ON**, you should call your installer or maintenance provider to have the system serviced.

The recommended frequency of solids removal should be every 3 – 4 years. Contact your installer for correct cleaning instructions.

MANUFACTURERS WARRANTY REGISTRATION CERTIFICATE

Owner/purchaser detach the certificate below and mail to the following address within thirty (30) calendar days of purchase:

SOLAR AIR

National Wastewater Systems, Inc
6754 Hwy 90 East
Lake Charles, LA 70615
(337) 439-0680

Purchaser's Record

Serial Number: _____

Date of Purchase: _____

Dealer's Name: _____

Address: _____

Telephone: _____

Registration Certificate

Serial Number: _____

Date of Purchase: _____

Owner/Purchaser: _____

Address: _____

Dealer's Name: _____

Address: _____

Telephone: _____

MANUFACTURERS LIMITED WARRANTY

NWSI warrants each wastewater treatment system to be free from defects in workmanship and materials from the date of installation for a period of no more than twenty-four (24) months. When properly installed and registered by the manufacturer or appointed representative, the manufacturers sole obligation under this warranty shall be as follows:

To repair or exchange any component, F.O.B. factory, that in the manufacturer's judgement is defective.

This warranty does not cover any system that has not been properly installed, been flooded by any external means, infested by ants, disassembled by any unauthorized person, anything other than normal household wastewater, or act of nature, this warranty applies only to the treatment system itself and does not include any of the purchasers plumbing, drainage and / or disposal system or house wiring.

The manufacturer is not nor claims responsibility for any delays or damages caused by defective components or materials, which cause losses, incurred by interruption of service or for repairs or replacements of component parts covered by the warranty.

If a purchaser or owner of a *SOLAR AIR* wastewater system wishes a continuing policy, with terms comparable to the initial service policy, it is available and can be obtained from the dealer for those purchasers or owners whose initial service policy has lapsed or expired.

SERVICE POLICY

The total purchase price of a *SOLAR AIR* includes a service policy of twenty-four (24) months. This policy includes all service calls required due to equipment failures, defects, or manufacturer defects.

The plant is to be inspected by the manufacturer or his representative every six months at no cost to the owner. These service calls or for the following:

1. Servicing of the unit will be available within two (2) working days of the owner's request.
2. Adjustment and servicing of the air blower including replacement or cleaning of the filter if necessary.
3. Examination of the aeration chamber and clarifier. Inspection of the mixture or aeration regime and for the presence of sour or offensive odors, color, and turbidity, scum and overflows.
4. Immediate notification of the owner / warrantee in writing of any improper observation which cannot readily be repaired. This notification will advise said owner of the problem and if it is covered by warranty, and estimated date for correction of said problem(s).

There shall be no charge to the owner for any service calls, repairs, or replacements of component parts covered by the warranty for 24 months from the date of installation.

If properly operated and maintained as stated the *SOLAR AIR* will meet or exceed all applicable standards and/or limitations as established by test as required by ANSI/NSF Standard No. 40 / (Class I).

SPECIFICATIONS

Designation: *SOLAR AIR*, Model SA 500
Single Family Residential Waste-Water Treatment System

Treatment Capacity/Class: 500 GPD/ (ANSI/NSF Class I)

BOD5 Loading: 1 – 1.5 lbs./day

COMPONENTS / MATERIAL CONSTRUCTION **MODEL SA - 500**

Tank: Manufactured out of concrete.
Concrete capable of withstanding 3,000 PSI.

Blower: Thomas Linear Series 5078S
Duty Rating - Intermediate

SOURCES FOR OBTAINING REPLACEMENT PARTS OR COMPONENTS

Replacement parts or components may be obtained from the installer or below:

SOLAR AIR
National Wastewater Systems, Inc
6754 Hwy 90 East
Lake Charles, LA 70615
(337) 439-0680

ELECTRICAL CONTROL PANEL

The electrical control panel must be a totally enclosed weatherproof box. The dimensions of which are: 5 ½” wide by 8 ½” long by 3 ½” deep. The electrical control panel is a Nema 4 box.

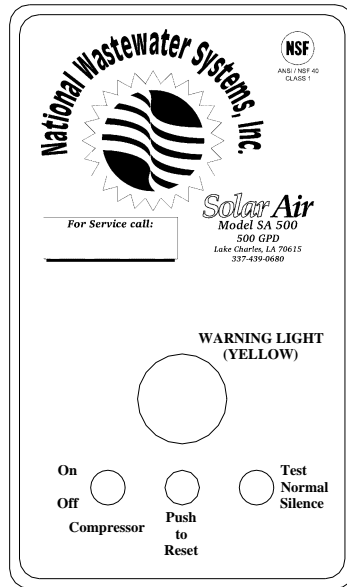

Field Wiring Section

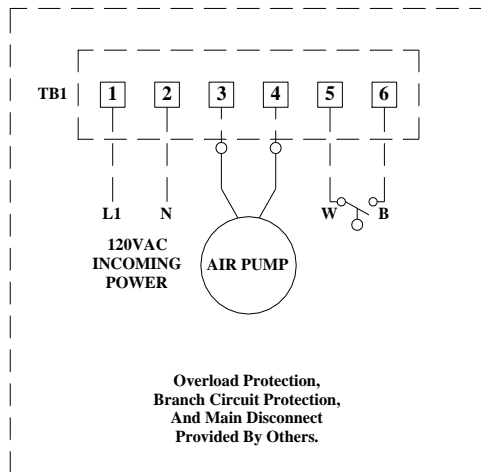

EQUIPMENT DATA PLATES

The aluminum 2.5" x 4" x .004" thick data plates and their information are permanently affixed to the blower motor housing.

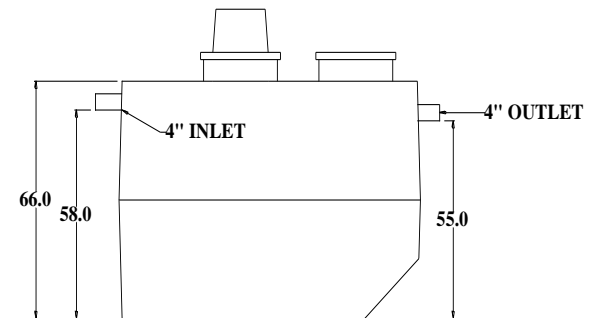
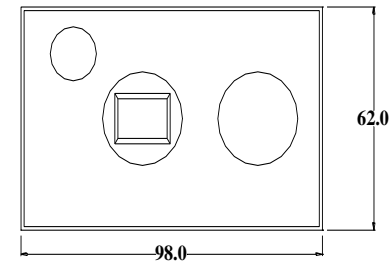
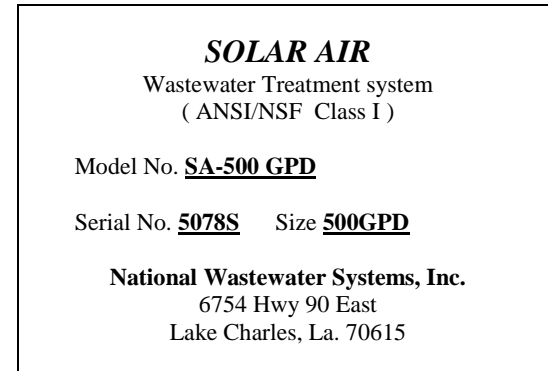

INSTALLATION DIAGRAM FOR SOLAR AIR
(SA 500)